



15P/30P Series

High Pressure Filters



ENGINEERING YOUR SUCCESS.

15P/30P Series

Applications

- Saw mills
- Aircraft ground support equipment
- Asphalt pavers
- Hydraulic fan drives
- Power steering circuits
- Waste trucks
- Cement trucks
- Servo control protection
- Logging equipment

These application examples have one thing in common... the need for clean hydraulic fluid.

Modern high pressure hydraulic systems are demanding. Better controls and long component life are expected. To deliver the high standards of performance, hydraulic components are built with tighter tolerances which increases their sensitivity to contamination.

That's where Parker pressure filters come into play. They filter out ingressed contamination before it jams a valve or scores a cylinder. They block pump generated debris before it gets to servo or proportional valves. Parker pressure filters are a key ingredient in meeting today's system demands.

Put your hydraulic systems in our care. We are committed to designing and building the best filters available to industry.

Indicators

Both visual auto reset style and dual indicator visual/electrical style available to suit your application.

Straight Thread Ports

SAE straight thread for positive sealing

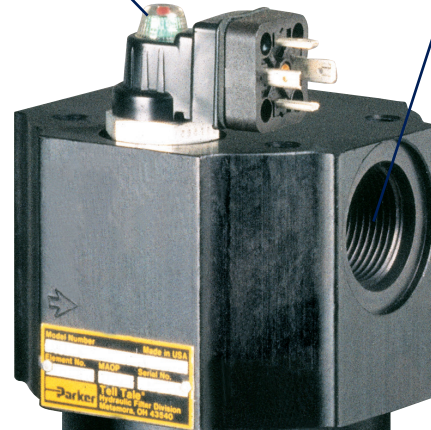

Bowl Construction

Formed of high grade 6061 T6 aluminum.

Powder painted, corrosion resistant finish.

Bypass Valve (not visible)

May be blocked for critical applications

Hex (not visible)

Hex formed at base of bowl for easy removal

Drain Port (not visible)

Clean and easy servicing

Lets you drain bowl before element changes

Bowl Configurations

Single and double length bowls available to cover a wide range of flows.

30P available in a duplex version.

15P/30P Series

Element Features

Quality elements make the difference

The important item in a filter assembly is the element. It must capture and retain contaminants that can damage system components. At the same time it must allow flow to pass as freely as possible to perform its function.

There are many ways to design and build an element, and it's easy to produce a low cost element. However, cost is not the only selection criteria, especially when the risk is loss of critical machine performance.

For instance, wire mesh reinforcement. Not all filter elements have it. It's used in Parker elements to keep the pleats from bunching or collapsing. If pleats bunch, the effective surface area of the element is reduced, excessive pressure drop develops, and the filter assembly may go into premature bypass mode.

There are many other features that are included standard with every quality Parker element. The table below outlines several.

O-Ring Seal

Positive sealing for optimum element efficiency

Wire Reinforced Media

Prevents pleat bunching
Helps prevent media migration
Maintains media efficiency



Engineered Element Design

The right combination of pleat depth and number of pleats means lower pressure losses (longer life)

Dirt holding capacity is maximized for less frequent element change-out

Elements for Every Application

Standard Microglass media for long life and excellent system protection

Feature	Advantage	Benefit
Wire reinforced Microglass elements	Rugged construction, stands up to abuse of cyclic flows without performance loss Wire support reduces pleat bunching, keeps pressure drops consistent	The reliable filtration provided assures equipment protection, reduces downtime, maximizes element life, and allows the hydraulic system to operate properly
Multipass tested elements (per ANSI/NFPA T3.10.8.8 R1-1990)	Filter performance backed by recognized and accepted laboratory test standards	Filters you select have known performance levels
Complete element performance data disclosure	All pertinent information is provided in an easy-to-compare format	Provides an easy guide to proper filter selection

15P Series

15P-1 Element Performance

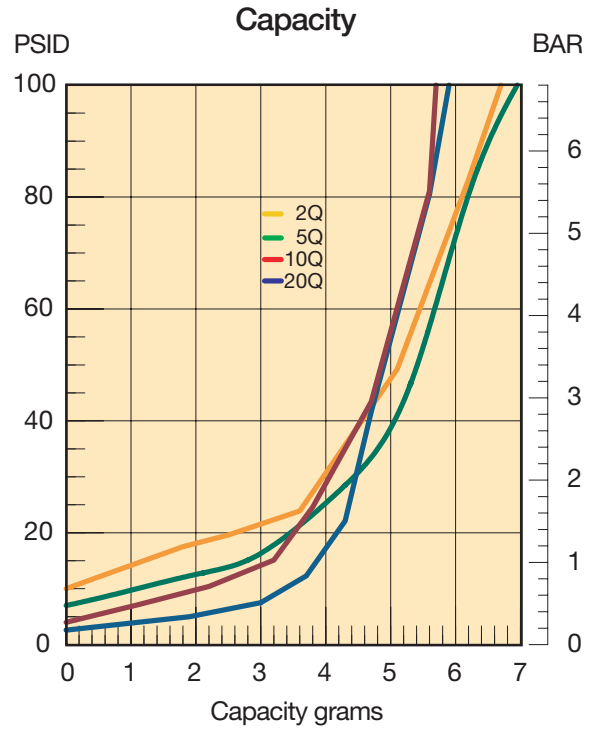
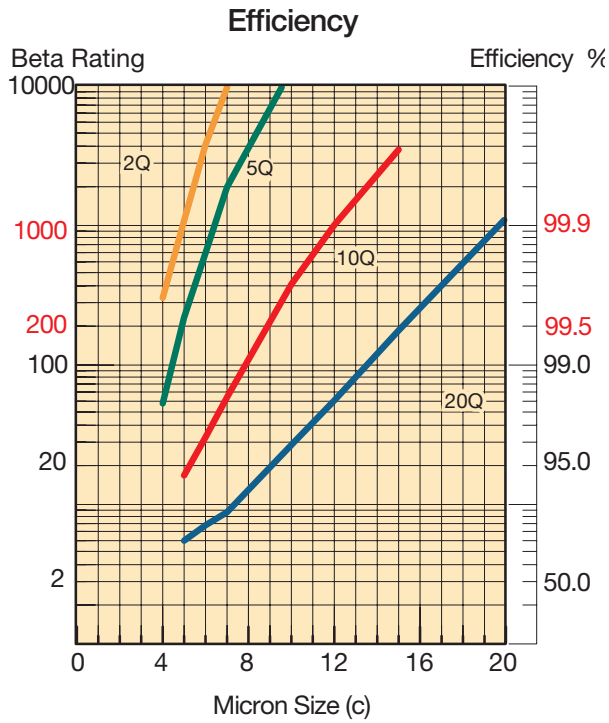

Results typical from Multi-pass tests run per test standard ISO 16889 @ 10 gpm to 100 psid terminal - 10 mg/L BUGL
Refer to Appendix for relationship to test standard ISO 4572.

*High Collapse Correction Factor:

QH Elements (2000 psid) = 1.4 times reported loss

Flow vs. Pressure Loss

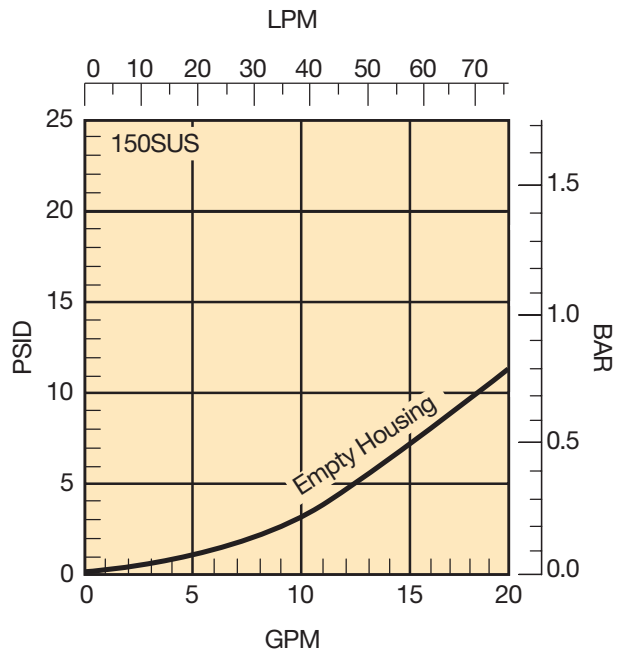
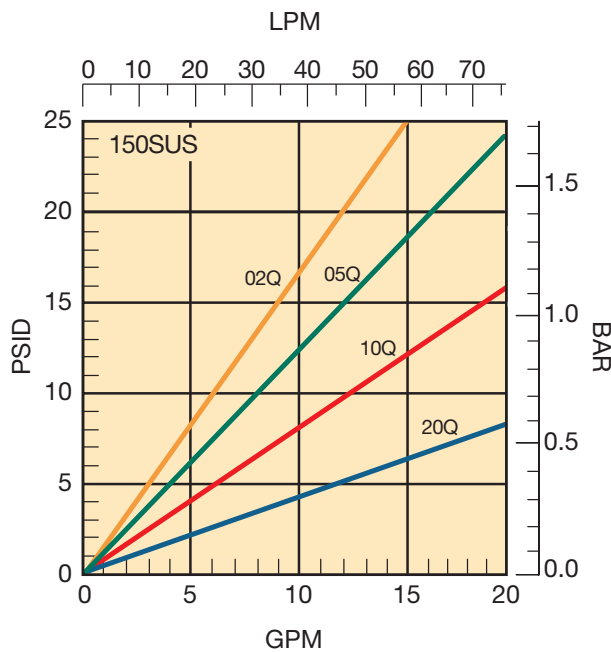

15P Series

15P-2 Element Performance

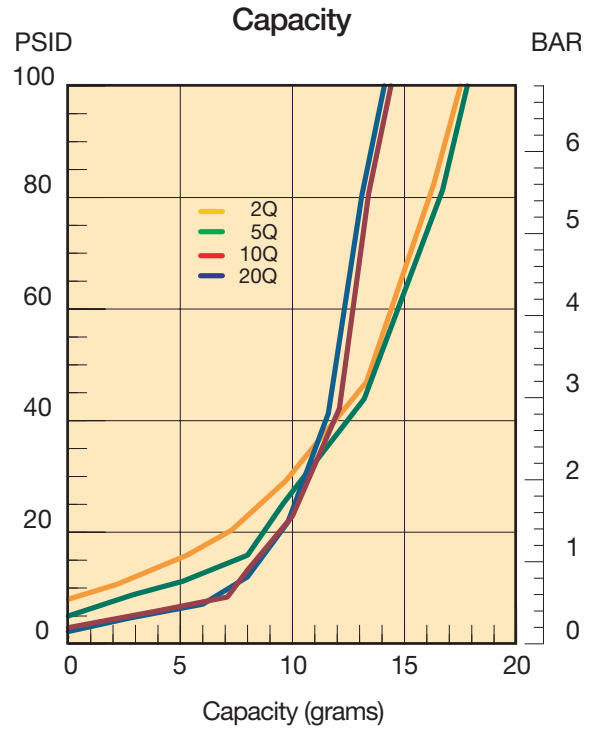
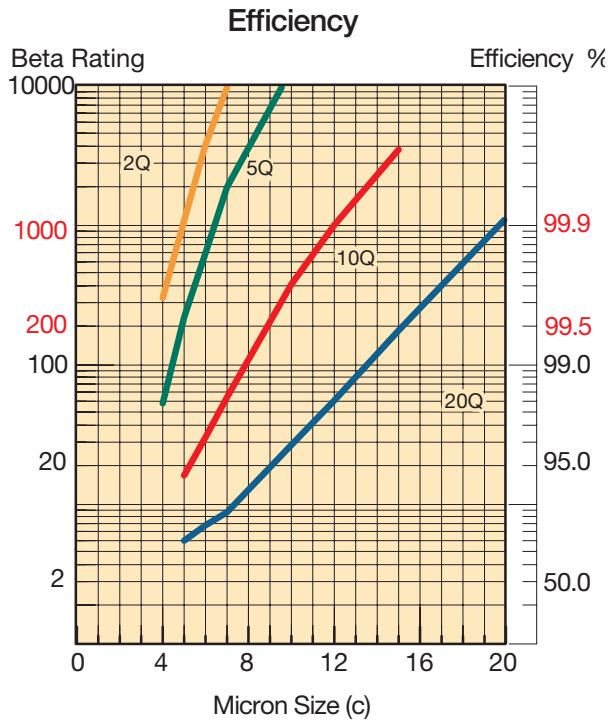

Results typical from Multi-pass tests run per test standard ISO 16889 @ 15 gpm to 100 psid terminal - 10 mg/L BUGL
Refer to Appendix for relationship to test standard ISO 4572.

*High Collapse Correction Factor:

QH Elements (2000 psid) = 1.4 times reported loss

Flow vs. Pressure Loss

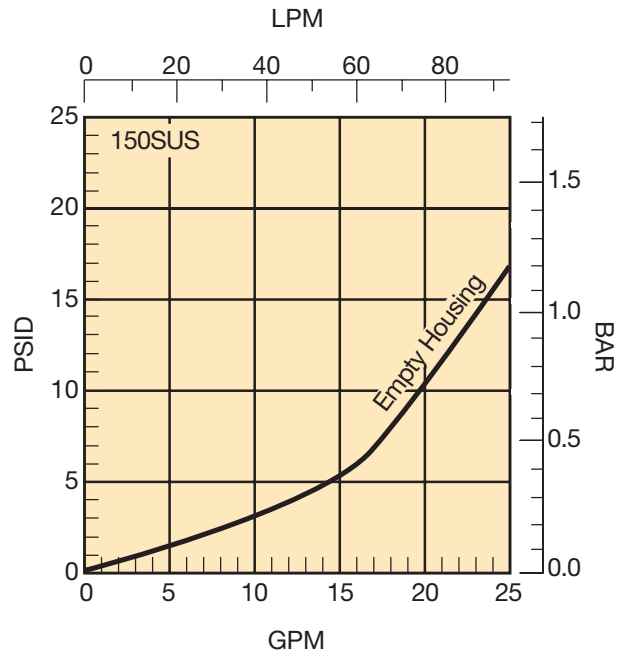
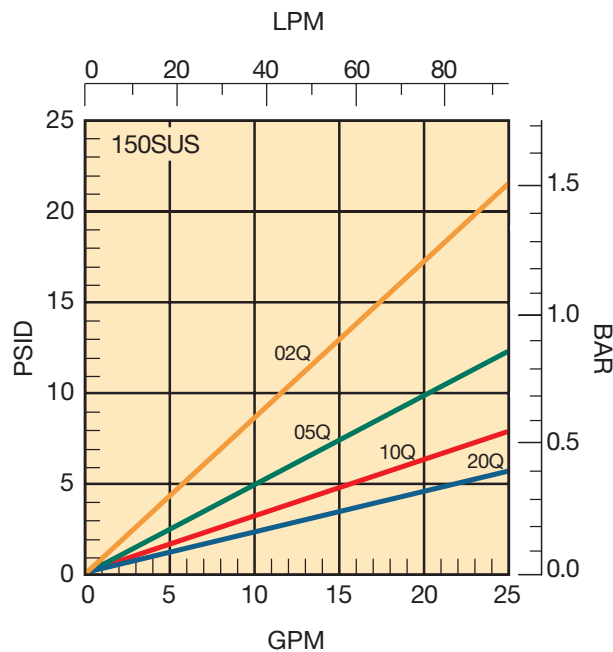

30P Series

30P-1 Element Performance

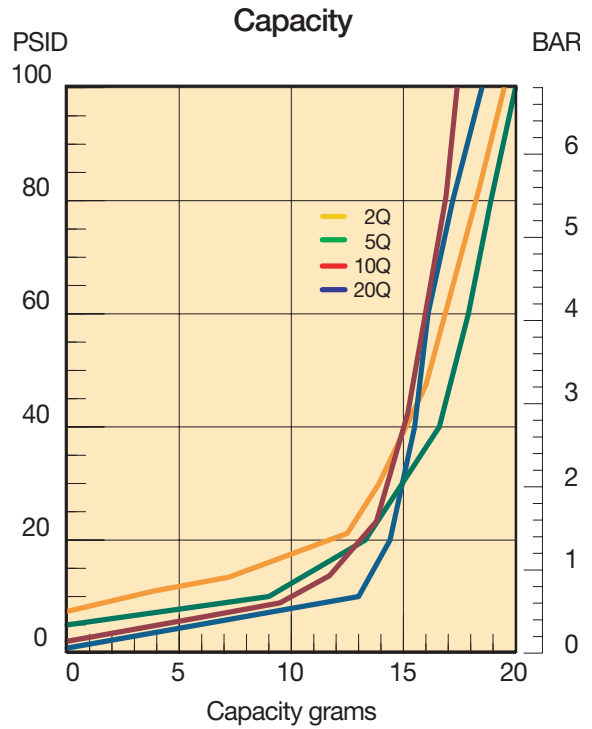
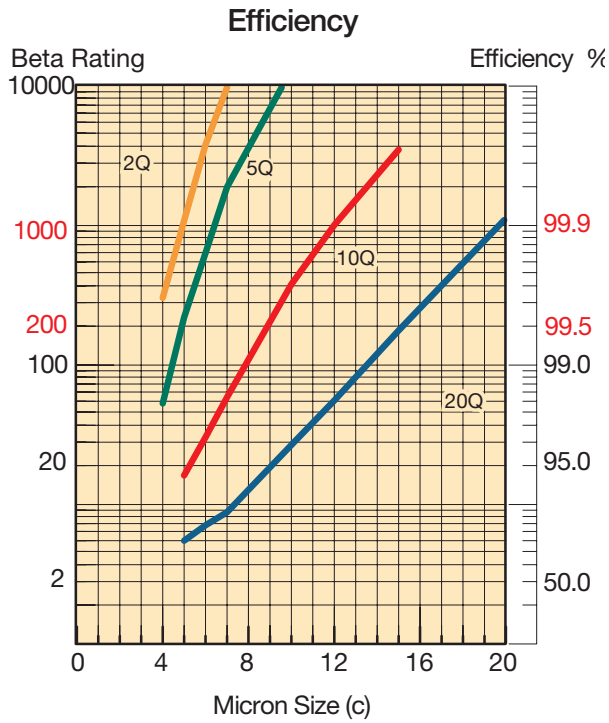

Results typical from Multi-pass tests run per test standard ISO 16889 @ 20 gpm to 100 psid terminal - 10 mg/L BUGL
Refer to Appendix for relationship to test standard ISO 4572.

*High Collapse Correction Factor:

*"QH" Elements (2000 psid) = 1.4 times reported loss

Flow vs. Pressure Loss

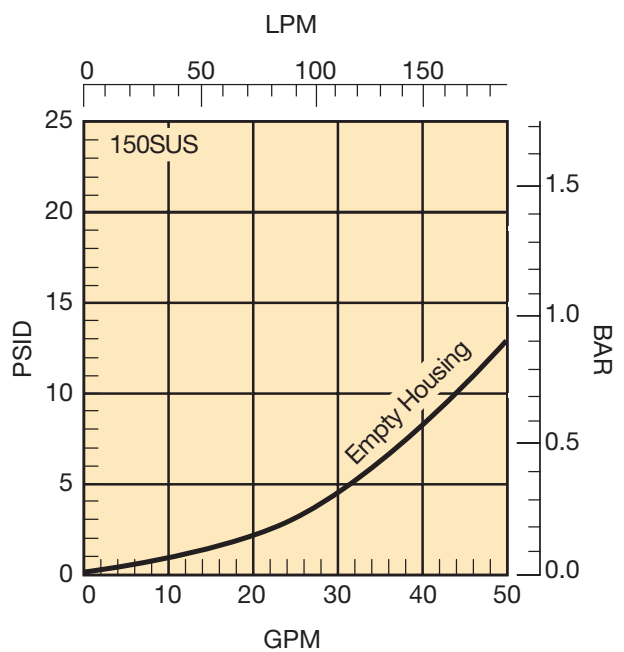
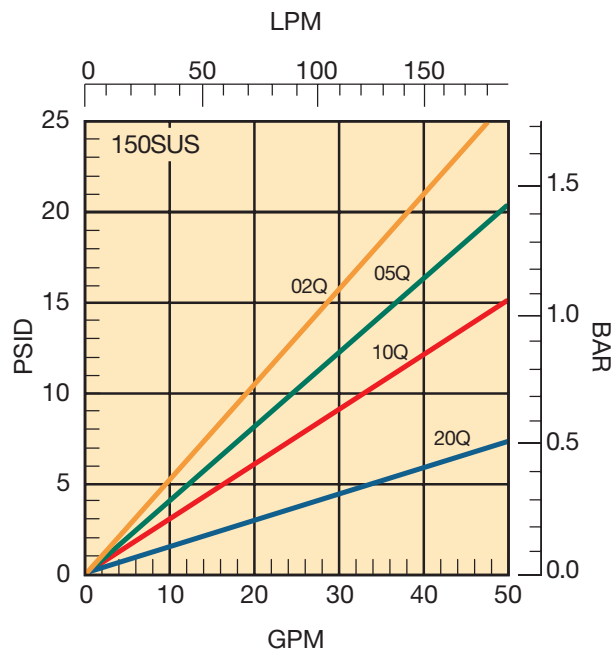

30P Series

30P-2 Element Performance

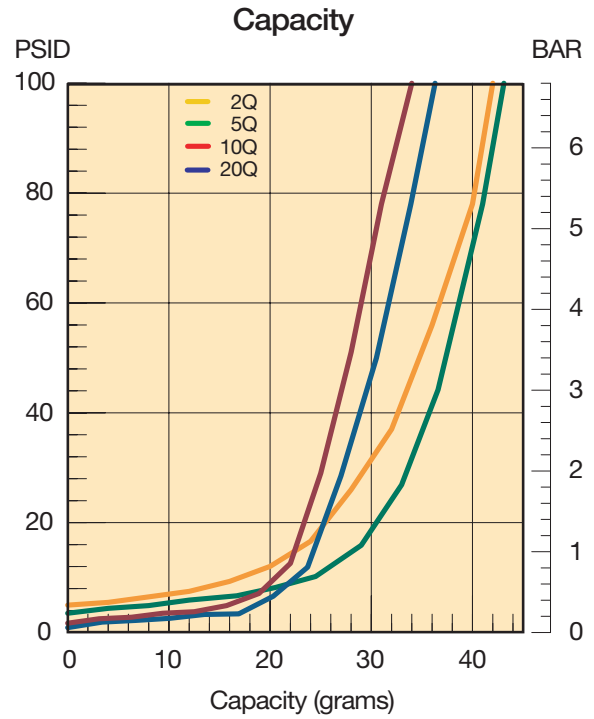
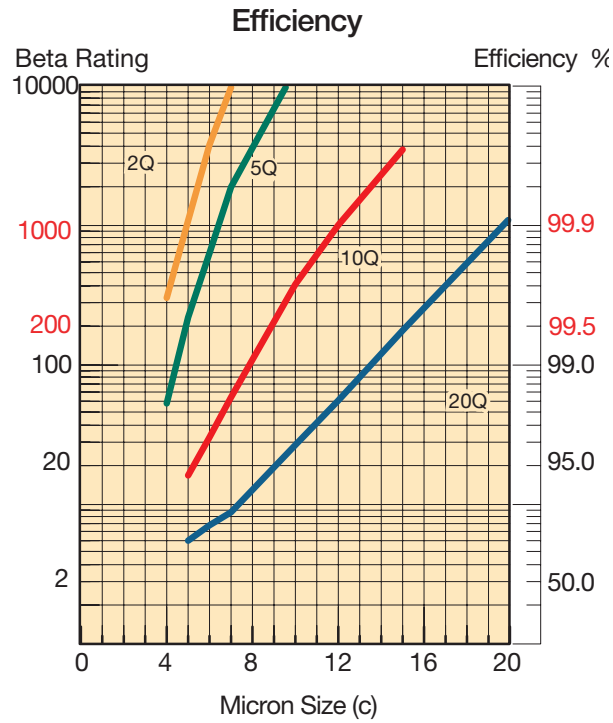

Results typical from Multi-pass tests run per test standard ISO 16889 @ 30 gpm to 100 psid terminal - 10 mg/L BUGL
Refer to Appendix for relationship to test standard ISO 4572.

*High Collapse Correction Factor:

*"QH" Elements (2000 psid) = 1.4 times reported loss

Flow vs. Pressure Loss

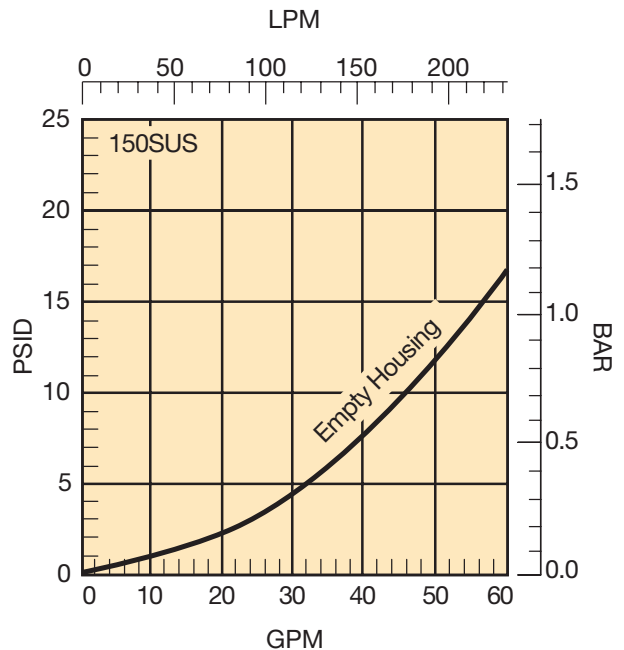
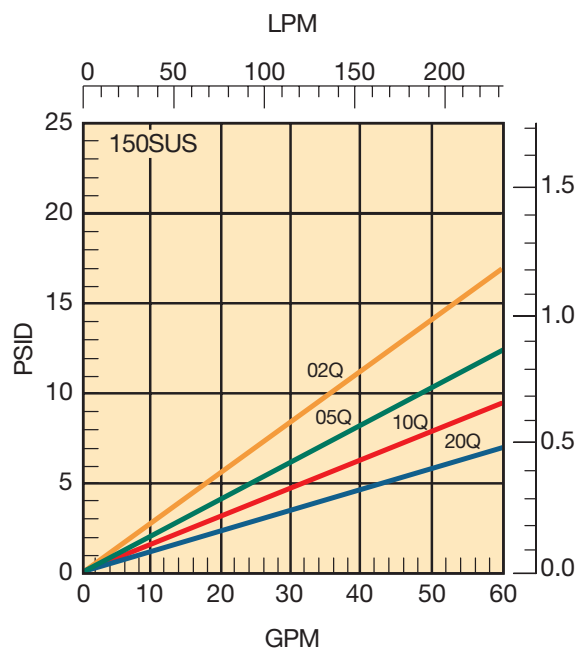

15P Series

Specifications

Pressure Ratings:

Maximum Allowable Operating Pressure (MAOP): 3000 psi (206.9 bar)
 Rated Fatigue Pressure: 2000 psi (138 bar)
 Design Safety Factor: 3:1

Operating Temperatures:

Buna: -40°F (-40°C) to 225°F (107°C)
 Fluorocarbon: -15°F (-26°C) to 275°F (135°C)

Element Collapse Rating:

Standard- 350 psid (24.1 bar)
 "H" Option- 2000 psid (138 bar)
 "X" Option- 3000 psid (206.9 bar)

Weights (approximate):

15P-1 3.5 lb. (1.6 kg.)
 15P-2 4.6 lb. (2.1 kg.)

Materials:

Bowl: impacted aluminum (6061-T6, black powder painted exterior)
 Head: extruded aluminum (anodized 6061-T6)
 Bypass: nylon

Element Condition Indicators:

Visual (optional) 360° green/ red
 Electrical/ Visual (optional)
 5A @ 240VAC, 3A @ 28VDC
 Electrical-heavy duty (optional)
 .25A (resistive) MAX 5 watts
 12 to 28 VDC & 110 to 175 VAC

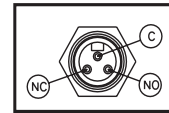

Model code option 'E3'

Color Coding:

White (common)
 Black (normally open)
 Blue (normally closed)

Linear Measure: **millimeter**
inch

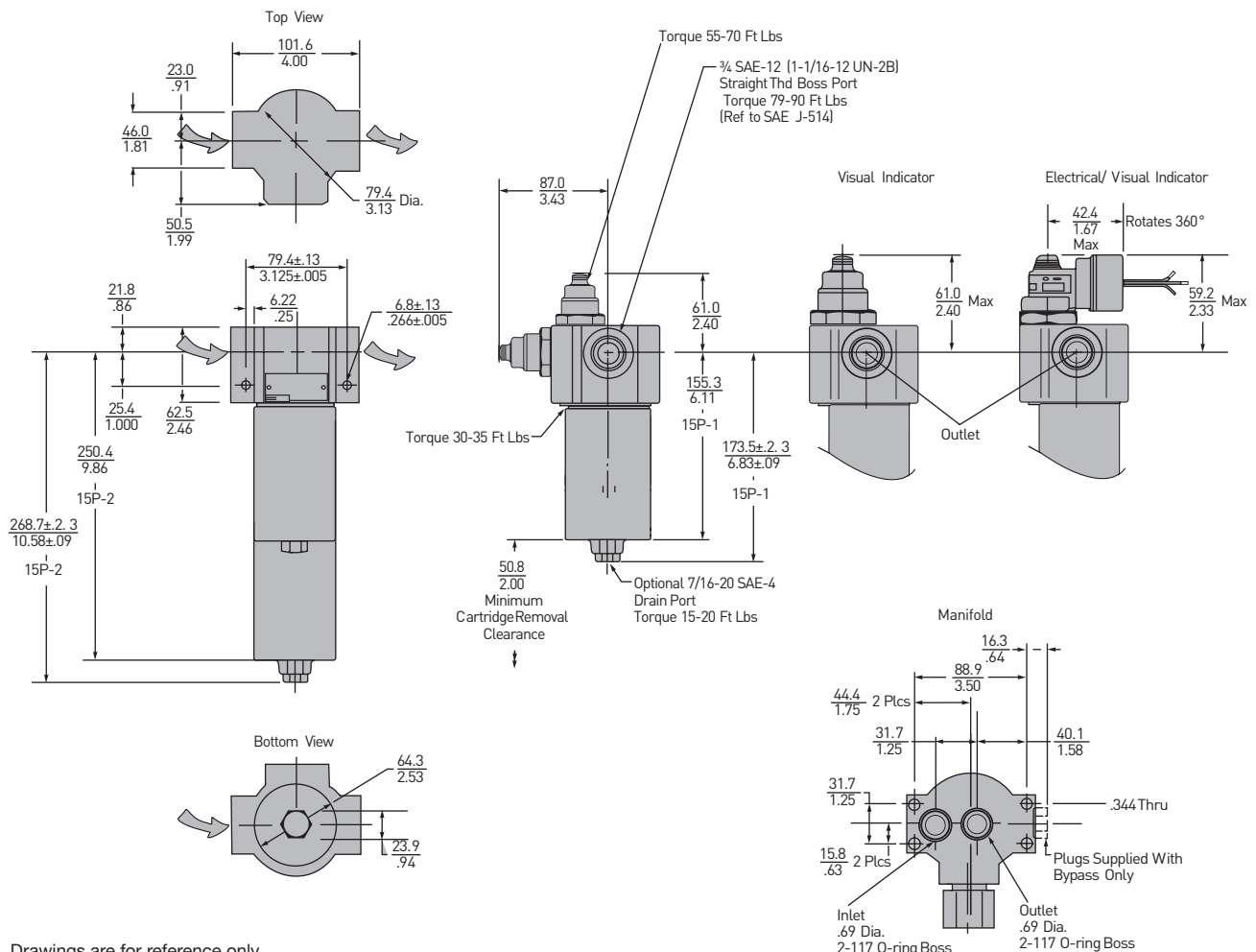

Drawings are for reference only.
 Contact factory for current version.

30P/30PD Series

Specifications

Pressure Ratings:

Maximum Allowable Operating Pressure (MAOP): 3000 psi (206.9 bar)
 Rated Fatigue Pressure: 2000 psi (138 bar)
 Design Safety Factor: 3:1

Operating Temperatures:

Buna: -40°F (-40°C) to 225°F (107°C)
 Fluorocarbon: -15°F (-26°C) to 275°F (135°C)

Element Collapse Rating:

Standard- 350 psid (24.1 bar)
 "H" Option- 2000 psid (138 bar)
 "X" Option- 3000 psid (206.9 bar)

Weights (approximate):

30P-1 6.4 lb. (2.9 kg.)
 30PD-1 36 lb. (16.3 kg.)
 30P-2 8.7 lb. (3.9 kg.)
 30PD-2 40 lb. (18.1 kg.)

Materials:

Bowl: impacted aluminum (6061-T6, black powder painted exterior)
 Head: extruded aluminum (anodized 6061-T6)
 Bypass: Nylon

Element Condition Indicators:

Visual (optional) 360° green/ red
 Electrical/ Visual (optional)
 5A @ 240VAC, 3A @ 28VDC
 Electrical-heavy duty (optional)
 .25A (resistive) MAX 5 watts
 12 to 28 VDC & 110 to 175 VAC

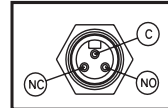

Model code option 'E3'

Color Coding:

White (common)
 Black (normally open)
 Blue (normally closed)

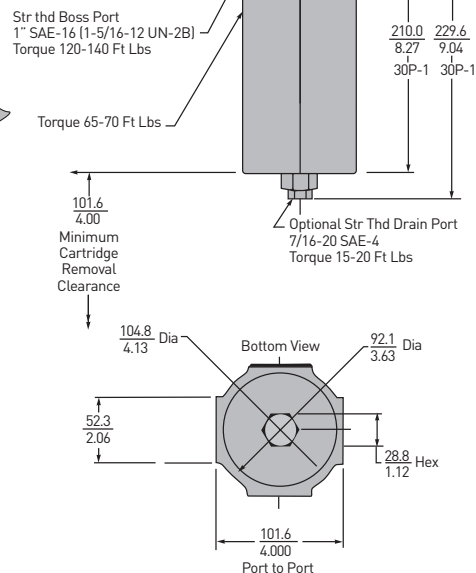
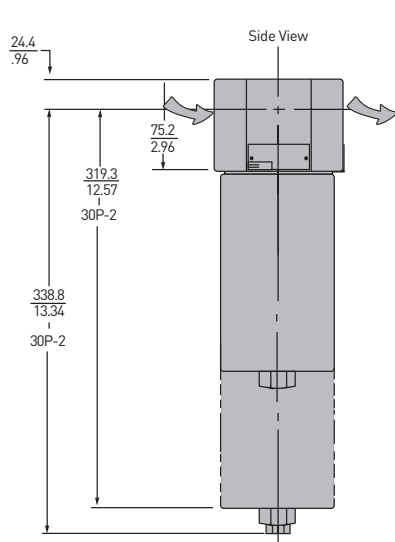
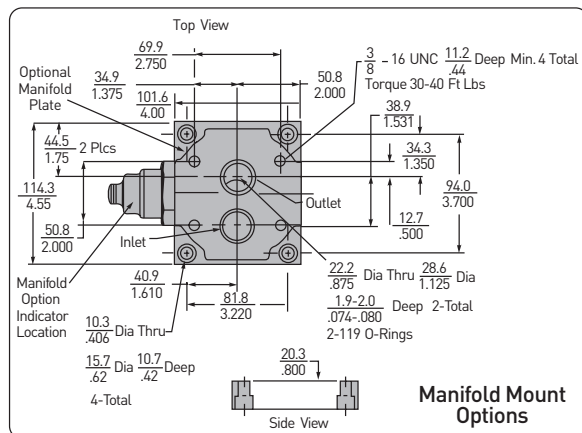

Linear Measure: millimeter inch

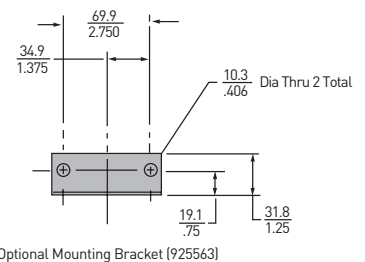
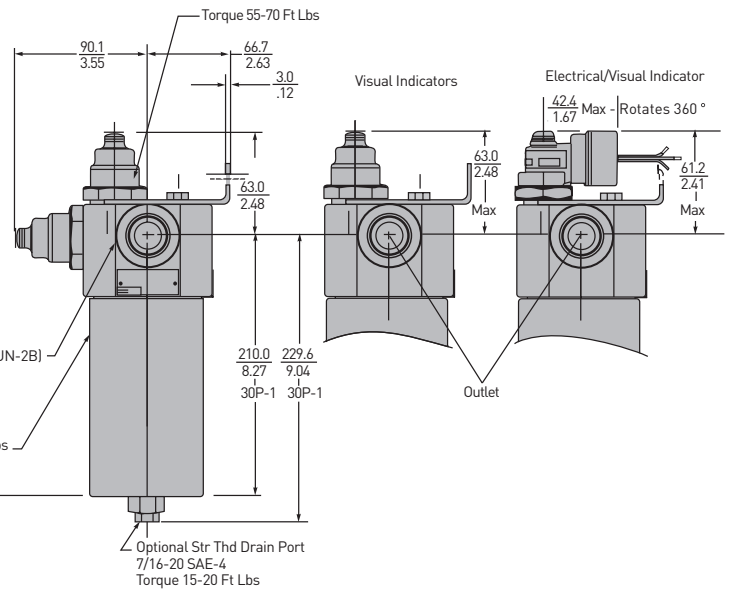

Drawings are for reference only.
 Contact factory for current version.

30P Duplex Filter

The Parker 30PD duplex pressure filter provides uninterrupted filtration for equipment that cannot be shut down for servicing.

The 30PD allows you to simply switch the diverter valve and service the element while the other side is in service.

Pressure balancing valves and check valves are all neatly assembled in a compact manifold head that makes operation safe, smooth and easy.

Vent valves are also included to insure that all air is purged during service so that maximum system performance is achieved.

The Parker 30PD makes use of industry proven components. Elements are multi-pass tested in accordance with ANSI/NFPA T3.10.8.8 R1 -1990. Bowls and head are subjected to rigorous fatigue testing to insure a trouble free service life.

Drawings are for reference only. Contact factory for current version.

Diverter Valve

Low torque for easy servicing
Detent for valve handle prevents accidental switching
Handle indicates which filter is in use

Vent Valves

Allow for convenient purging of trapped air, and pressure

Ports

SAE straight thread ports for positive sealing

Balance Valve

Safety valve equalizes pressure between the two bowls

Operating Instructions

Name tag and operating instructions riveted to manifold

Vent Drains

1/8-27 NPT drain port, both sides

30PD Empty Housing Flow vs Pressure Loss

To obtain total filter assembly pressure loss, add empty housing loss to the pressure loss of selected element on 30P element performance pages.

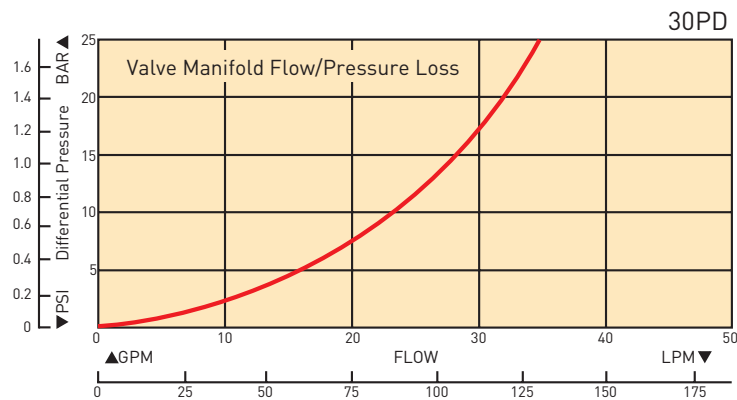

Installation Dimensions

Linear Measure: millimeter
inch

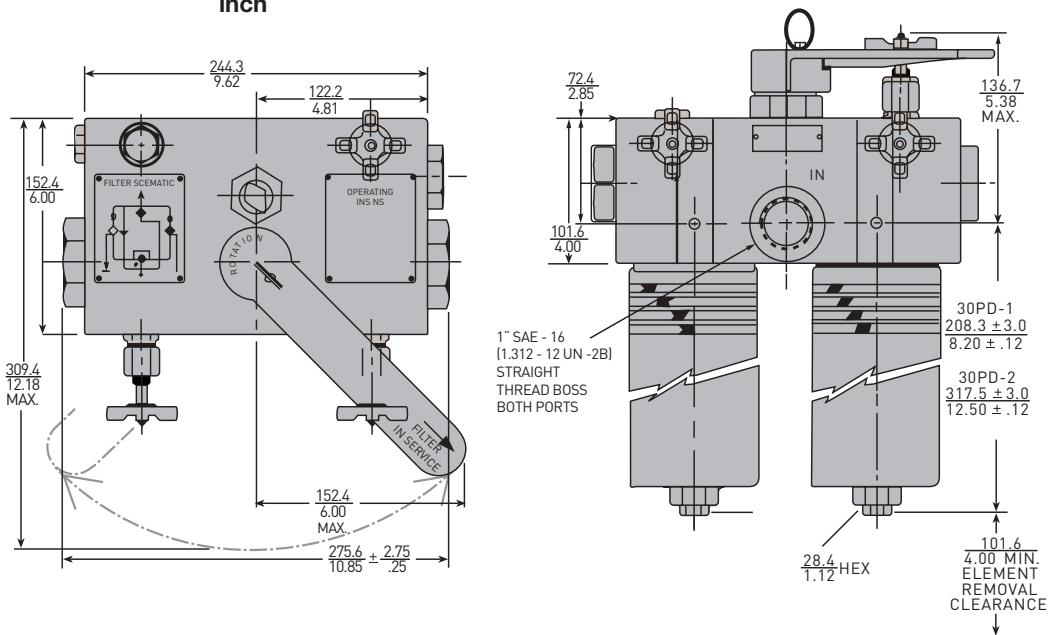

15P/30P Series

Parts List

Index	Description	15P	30P
1	Head		
	In-line porting		
	Bypass w/ top indicator port	931520	933956
	No bypass w/ side indicator port	931519	933956
	Bypass w/ side indicator port	931522	933955
	No bypass w/ side indicator port	931521	933955
	Manifold Porting		
	Bypass w/ indicator port	931135	933954
	No bypass w/ indicator port	931523	933954
2	Bypass valve assembly		
	50 psid (in-line model only)	928981	925127
	No bypass	935744*	925209
3	Elements (see chart on model code page)		
4	Bowl & Dust Seal O-ring		
	Nitrile	N92138	N92151
	Fluorocarbon	V92138	V92151
5	Bowl		
	Single w/out drain	937547	937551
	Single w/ drain	937549	937553
	Double w/ out drain	937548	937552
	Double w/ drain	937550	937554
6	Drain plug, SAE-4		
	w/ nitrile o-ring	921088	921088
	w/ fluorocarbon o-ring	928882	928882
7	Nameplate (unstamped)	920928	920928
8	Drive Screws	903393	903393
9	Mounting spacer tube (not shown)	925650	N/A
10	Mounting bracket kit	N/A	925563
11	Blank indicator kit	925515	925515
12	Indicators (fluorocarbon seals)		
	Visual auto reset	932027	932027
	H option (1/2" conduit connection)	932905	932905
	E2 option (DIN 43650 connection)	929599	929599
	E3 option (3 pin ANSI/B93.55M connection)	929596	929596
13	Manifold mounting kit	N/A	925562
	Manifold o-ring (2 required)		
	Nitrile	N92117	N92119
	Fluorocarbon	V92117	V92119

Note: consult factory for EPR part numbers

*Not for manifold-style head

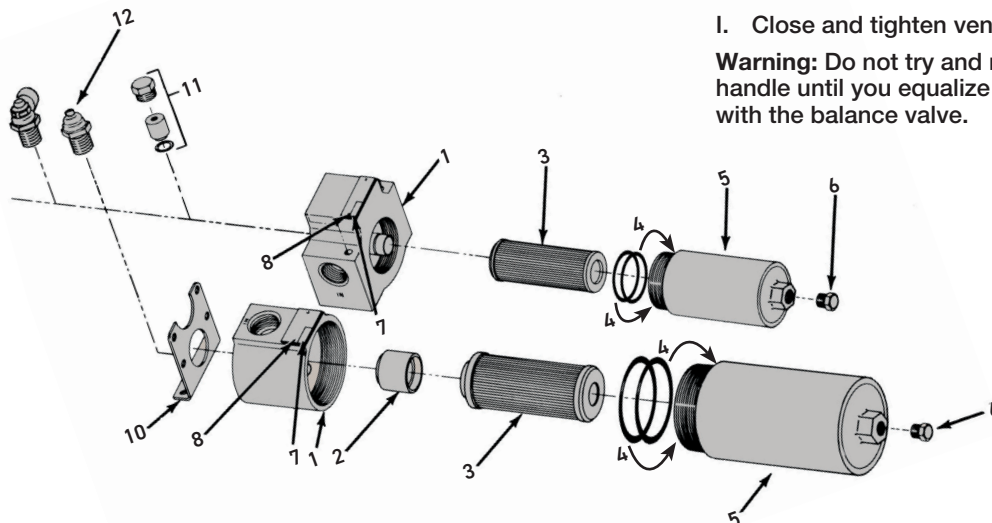

Element Servicing

15P/30P

- Stop the system's power unit.
- Relieve any pressure in the filter line and drain filter bowl if drain port is provided.
- Loosen and remove bowl.
- Remove element from housing.
- Place new, clean element in housing, centering it on the element locator.
- Inspect the bowl & dust seal o-rings and replace if necessary.
- Install bowl and tighten to specified torque.

30PD

- Arrow on diverter handle points to the on-duty chamber.
- Open off-duty vent valve (vent port should be plumbed back to reservoir).
- Open balance valve slowly to admit fluid into off duty chamber.
- When fluid is discharged from vent port, close and tighten.
- Pull up on detent pin and rotate diverter approximately 90° until detent relocates in seat.
- Close and tighten balance valve.
- Open new off-duty vent valve to relieve pressure.
- Follow steps C-G from 15P/30P instructions above.
- Close and tighten vent valve.

Warning: Do not try and rotate handle until you equalize pressure with the balance valve.

15P/30P Series¹

High Pressure Duplex Filters

How To Order

Select the desired symbol (in the correct position) to construct a model code. Example:

BOX 1	BOX 2	BOX 3	BOX 4	BOX 5	BOX 6	BOX 7	BOX 8
30P	1	10Q	E	M2	K	S16	4

BOX 1: Filter Series	
Symbol	Description
15P	Pressure Filter
30P	Pressure Filter
30PD	Duplex style 30P

BOX 2: Element Length	
Symbol	Description
1	Single
2	Double

BOX 3: Media ^{2,3}	
Symbol	Description
02Q	Microglass, 2 micron
05Q	Microglass, 5 micron
10Q	Microglass, 10 micron
20Q	Microglass, 20 micron

Add H to element code for high collapse (2,000 psid)

Add X to element code for high collapse (3,000 psid) 02 Q and 10Q media only.

BOX 4: Seals	
Symbol	Description
B	Nitrile
E	Ethylene propylene
V	Fluorocarbon

BOX 5: Indicators	
Symbol	Description
P	Indicator pressure port only
M2	Visual auto reset
E2	Electrical/visual (DIN 43650 style connector)

Note: For side mount indicators, place a "S" after indicator symbol. Not available on 30PD model.

BOX 6: Bypass & Indicator Setting ⁴	
Symbol	Description
K	50 PSI (3.5 bar)

BOX 7: Ports	
Symbol	Description
15P	
S12	SAE-12
X ⁵	3/4" manifold port
30P	
S16	SAE-16
X ⁵	1" manifold port
30PD	
S16	SAE-16

BOX 8: Options	
Symbol	Description
1	None
2	No bypass
4	SAE-4 drain port on bowl
21	No bypass and drain port

- Filters include the element you select already installed.
- The high collapse element is recommended when the no-bypass option is selected.
- "H" high collapse option not available with 20Q.
- If indicator and no bypass are selected, indicator setting is 50 psid.
- Customer supplies subplate for 30P manifold porting or may purchase 925562 30P subplate kit. 15P requires no subplate.

Replacement Elements (Fluorocarbon)

Media	15P-1	15P-2	30P/30PD-1	30P/30PD-2
02Q	932610Q	932616Q	932622Q	932628Q
05Q	932611Q	932617Q	932623Q	932629Q
10Q	932612Q	932618Q	932624Q	932630Q
20Q	930369Q	930370Q	933135Q	933136Q
02QH	932613Q	932619Q	932625Q	932631Q
05QH	932614Q	932620Q	932626Q	932632Q
10QH	932615Q	932621Q	932627Q	932633Q
20QH	934983Q	930544Q	NA	NA
02QX	933576Q	933578Q	933580Q	933582Q
10QX	933577Q	933579Q	933581Q	933583Q

